

1.ELECTRICAL:

- 2-1.Contact current rating:5A(Max)
- 2-2.Contact rated voltage:30VAC
- 2-3.Contact resistance:Initial:Power Pin 30mohm max, other contacts Pin40mohm max, after durability:change of +10mohm
- 2-4.Insulationn resistance:100 Mohm Min
- 2-5.Withstanding strength:100V AC For 1Minute

2.Material & Finish:

- Shell :Sus304,50U" NI plating over all.
- Contact: C7025,3U"min Au plating on concact area, 30 U" Tin(min) plating on solder area(DIP contact), 1U" Au plating on solder area(SMT contact), NI 30U"min under plating over all.

3:MECHANICAL CHARACTERISTICS:

- 2-1:MATING FORCE:5~20N
 - 3-2:UNMATING FORCE:8~20N(INITIAL), 6~20N(AFTER 10000 CYCLES)
 - 3-3:FREQUENCE: 200±50 CYCLES /HOUR,10000 CYCLES
 - 3-4:OPERATING TEMPERATURE ;-40~80°.
- 4: WATERPROOF: IP-X7.

| | | | |
|-----|-------------------|----------|--------------|
| 设计: | Arvin: 2016.03.08 | 范围 Range | 公差 Tolerance |
| 审核: | Arvin: | X.X ± | X.X ±0.30 |
| 校对: | Ru yi: | X.XX ± | X.XX ±0.20 |
| 比例: | 视角关系: | X.XXX ± | X.XXX ±0.10 |
| 版次: | 图框大小: A4 | Angle ± | Angle ±5° |

东莞市恒祺电子科技有限公司

名称:TYPE-C 料号:
 形号: 24PIN前插后贴沉板1.1防水款
 共 张 , 第 张 备注:

防水圈尺寸示意图

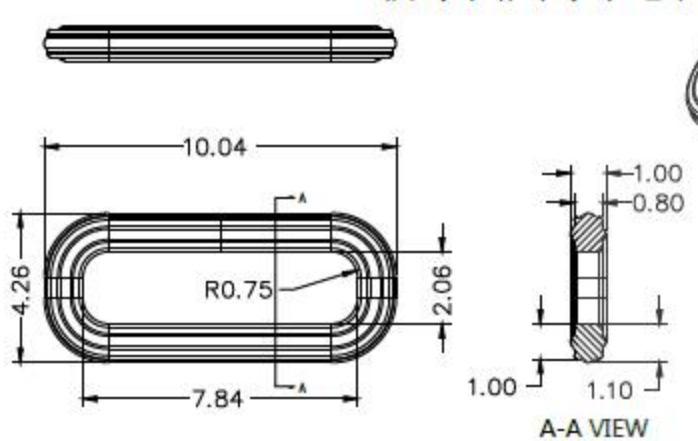

- 材质技术要求:
- 1、适合过回流焊工艺, 耐高温260℃;
 - 2、工作温度: -40℃ +80℃;
 - 3、环保、防漏水、不易老化变质, 自然条件下不溶化;
 - 4、零件表面光洁, 不允许有气孔, 毛边;
 - 5、硬度:
 - 6、颜色: 蓝色, 不可有杂色斑点;

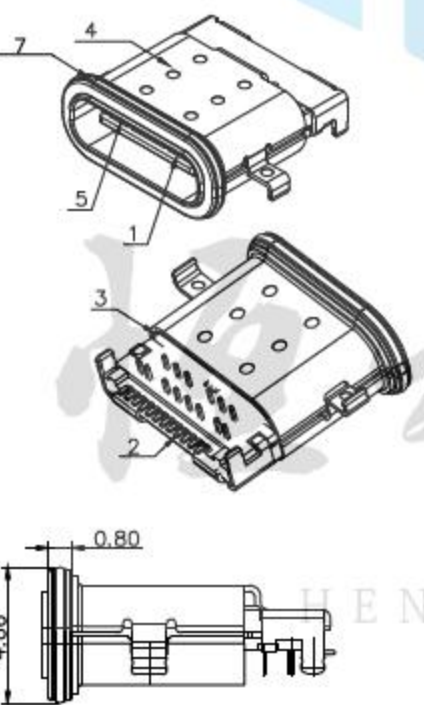

装防水圈后尺寸示意图

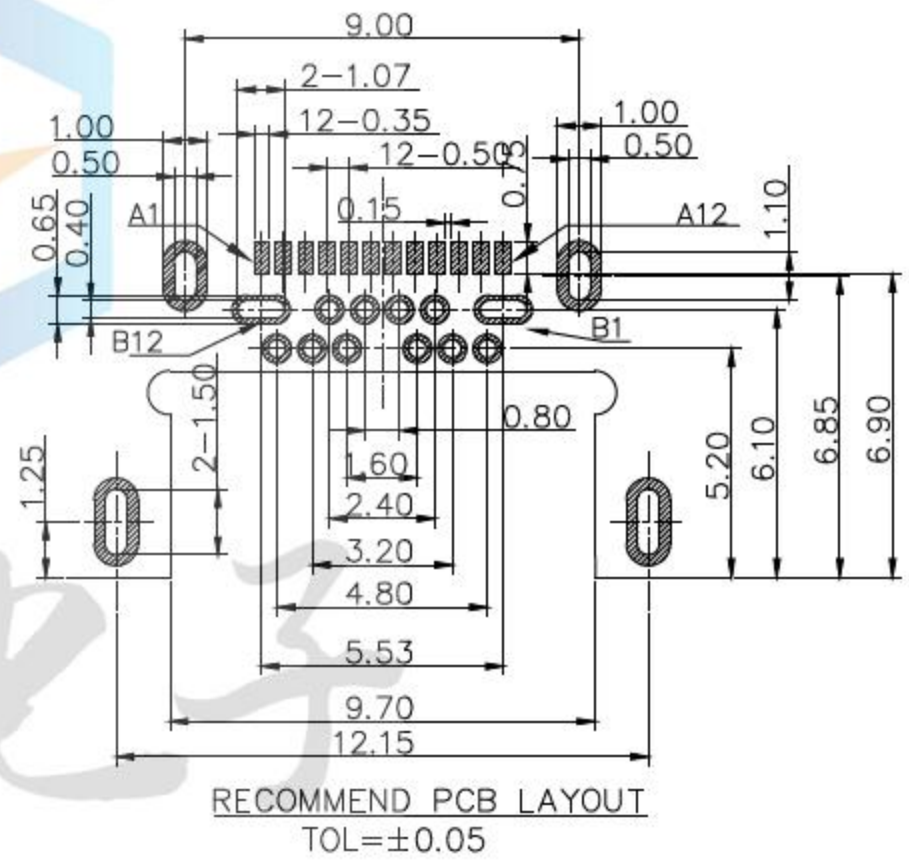
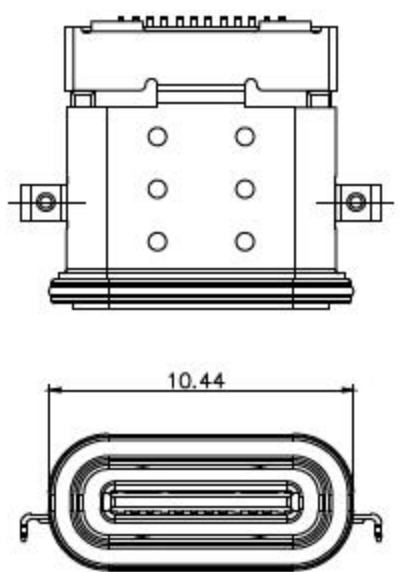

恒祺电子
HENG QI DIAN ZI

| | | | | | |
|-----|-------------------|----------|--------------|-----------------------|-----|
| 设计: | Arvin: 2016.03.08 | 范围 Range | 公差 Tolerance | 东莞市恒祺电子科技有限公司 | |
| 审核: | Arvin: | X.X ± | X.X ±0.30 | | |
| 校对: | Ru yi: | X.XX ± | X.XX ±0.20 | 名称: TYPE-C | 料号: |
| 比例: | 视角关系: | X.XXX ± | X.XXX ±0.10 | 形号: 24PIN前插后贴沉板1.1防水款 | |
| 版次: | 图框大小: A4 | Angle ± | Angle ±5° | 共 张, 第 张 | 备注: |