

RECOMMENDED PCB LAYOUT(TOP VIEW)

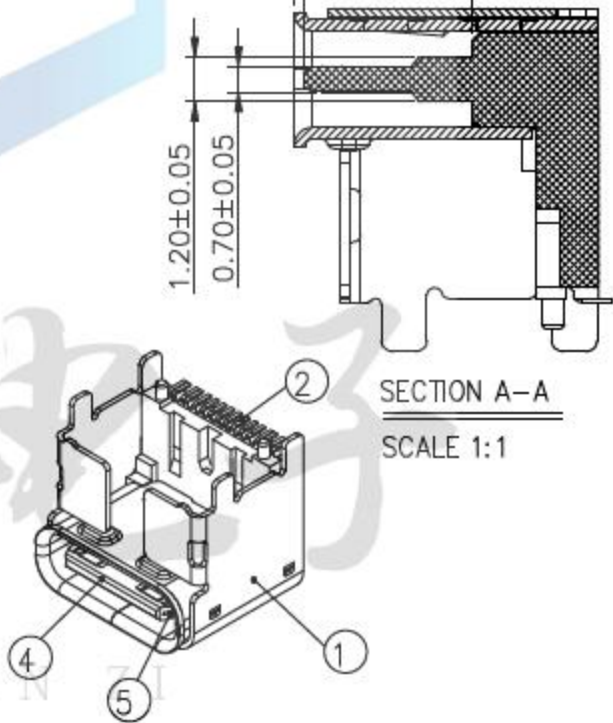
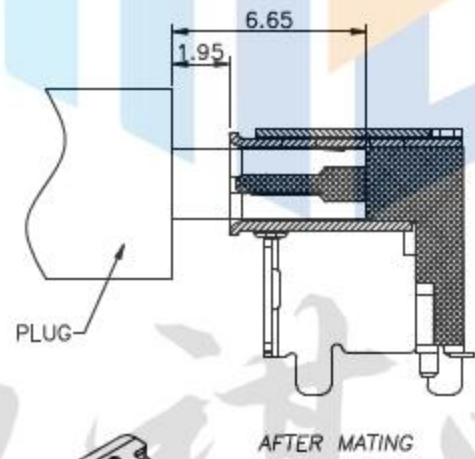
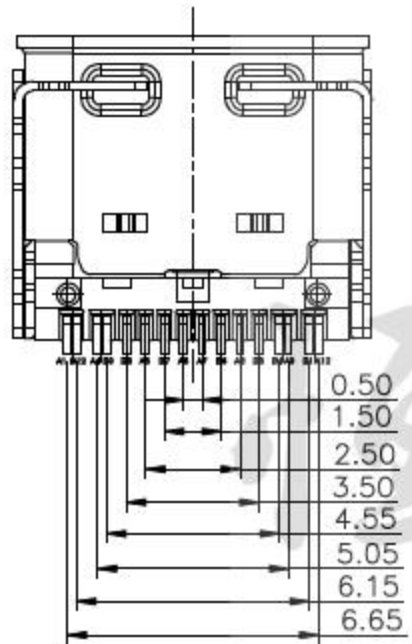

- NOTE:
- Electrical Characteristics:
 - 1-1: Current Rating: 5A For Pin(A4,A9,B4,B9)
1.25A For Pin(B5)
0.25A For Others Pin
 - 1-2: VOLTAGE RATING:5.0V
 - 1-3: Insulation Resistance: 100MΩ Min.
 - 1-4: Contact Resistance:
VBUS & GND PINS AND OTHER PINS: 40mΩ/PIN MAX.
SHIELD:50mΩ/MAX.
SHIELD:LLCR MAX. CHANGE OF ALL PINS: 10mΩ.
 - 1-5: Dielectric Withstanding Voltage: 100V/AC 1Minute
 - Mechanical Characteristics:
 - Insertion Force: 5~20N
 - Extraction Force: Initial: 8~20N
After durability: 6~20N
 - Durability :10000 Cycles
 - Operating Temperature: -25°C TO +85°C

HENG QI DIAN

设计:	Arvin: 2016.03.08	范围 Range	公差 Tolerance
审核:	Arvin:	X.X ±	X.X ±0.30
校对:	Ru yi:	X.XX ±	X.XX ±0.20
比例:	视角关系:	X.XXX ±	X.XXX ±0.10
版次:	图框大小: A4	Angle ±	Angle ±5°

东莞市恒祺电子科技有限公司

名称:TYPE-C 料号:
形号: 16PIN贴片垫高4.3
共 张 , 第 张 备注: