

印制板安装孔图

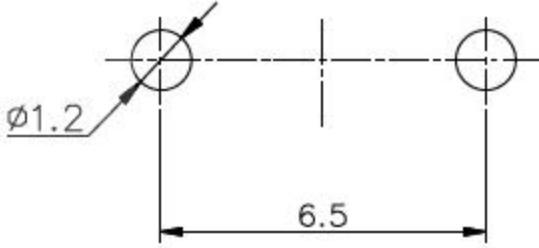

电路图

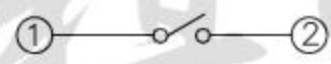

1. Operating temperature range: -30°C to 85°C
2. Rating: DC12V 50mA
3. Insulation resistance: $100\text{M}\Omega$ min 100V DC
4. Dielectric strength: 250V AC for 1min
5. Contact resistance: $100\text{m}\Omega$ Max
6. Operating force: $160 \pm 50\text{gf}$ - $260 \pm 50\text{gf}$
7. Travel: $0.25 \pm 0.10\text{mm}$
8. Operating life: 260gf 100,000 Cycle

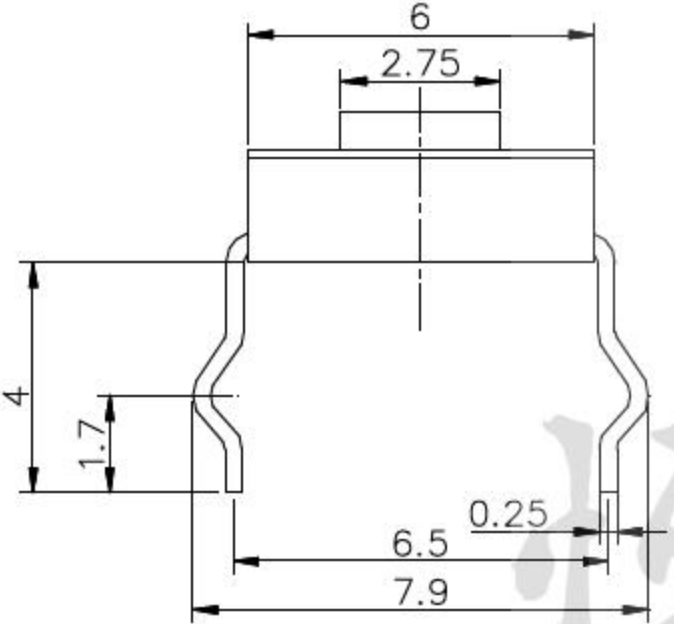
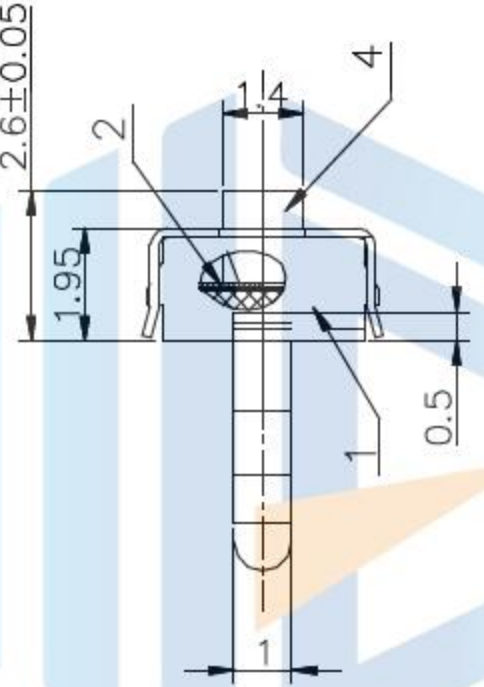
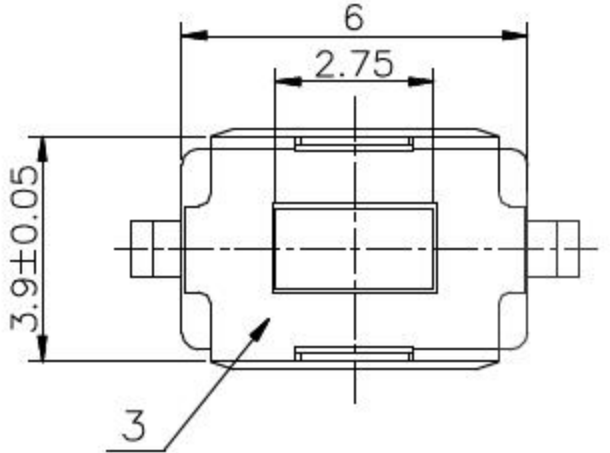

| | | | | | |
|-----|-------------------|----------|--------------|---------------|-----|
| 设计: | Arvin: 2016.03.08 | 范围 Range | 公差 Tolerance | 东莞市恒祺电子科技有限公司 | |
| 审核: | Arvin: | X.X ± | X.X ±0.30 | | |
| 校对: | Ru yi: | X.XX ± | X.XX ±0.20 | 名称: 轻触开关 | 料号: |
| 比例: | 视角关系: | X.XXX ± | X.XXX ±0.10 | 型号: TS-B008 | |
| 版次: | 图框大小: A4 | Angle ± | Angle ±5° | 共 张 , 第 张 | 备注: |