

**RoHS  
COMPLIANT**

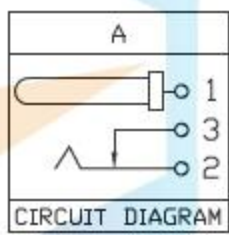

RECOMMENDED PCB LAYOUT  
TOLERANCE: ±0.05  
(TOP VIEW)

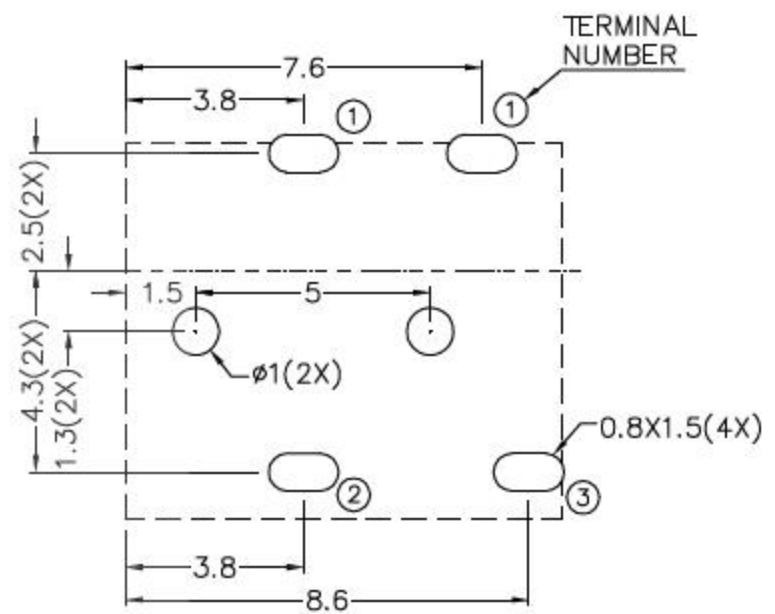
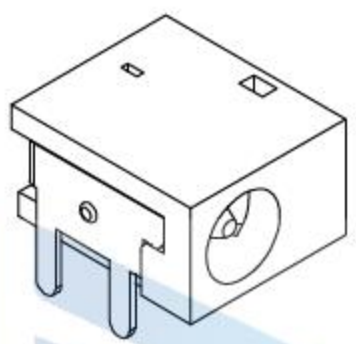
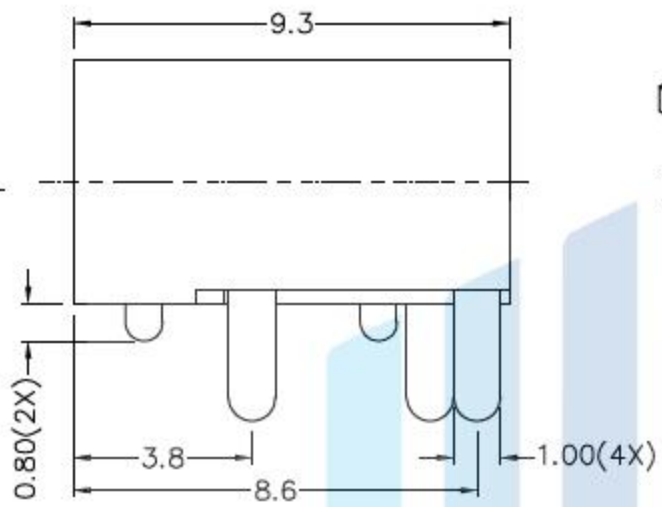
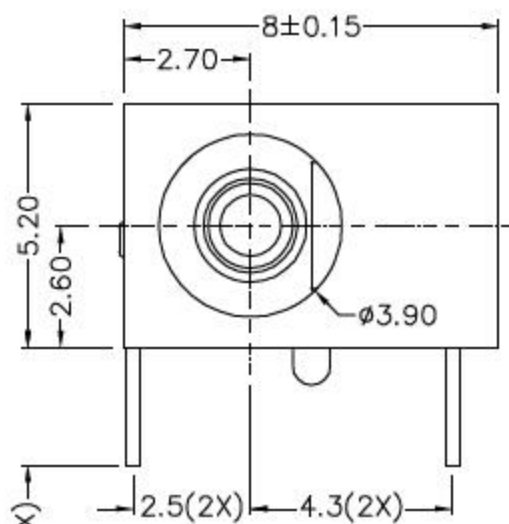
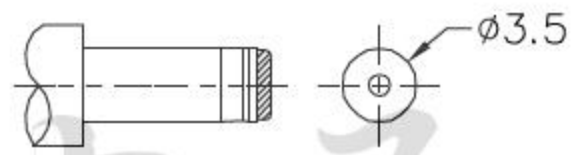
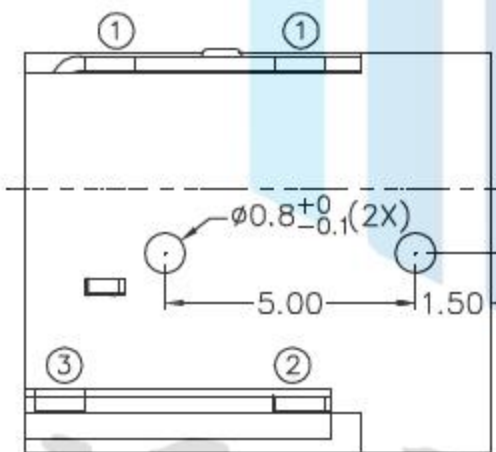
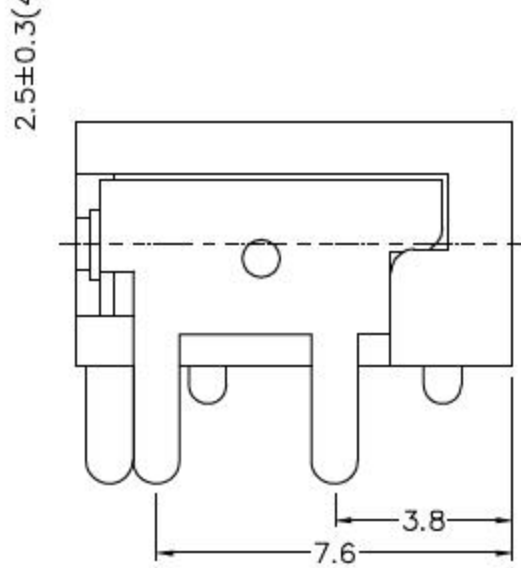

|            |        |        |
|------------|--------|--------|
| MODEL NO.  | C      | E      |
| CENTER PIN | ∅1.0mm | ∅1.3mm |

DC MATE PLUG

**技术要求**  
 使用条件: -40 ~ 55°C  
 额定负荷: DC 30V 0.5A  
 接触电阻: < 0.03Ω  
 绝缘电阻: > 100MΩ DC250V  
 耐压: AC 500V (50Hz) /min  
 插拔力: 3 ~ 20N  
 机械寿命: 5000次

|     |                   |          |              |
|-----|-------------------|----------|--------------|
| 设计: | Arvin: 2016.03.08 | 范围 Range | 公差 Tolerance |
| 审核: | Arvin:            | X.X ±    | X.X ±0.30    |
| 校对: | Ru yi:            | X.XX ±   | X.XX ±0.20   |
| 比例: | 视角关系:             | X.XXX ±  | X.XXX ±0.10  |
| 版次: | 图框大小: A4          | Angle ±  | Angle ±5°    |

**东莞市恒祺电子科技有限公司**

名称: DC插座      型号: DC-033A

料号:  
共 张 , 第 张      备注: